

Why 108 GVKEMRI Innovation ?

- 75,000 emergencies occur per day
 - 80% are at the bottom of the pyramid
 - 80% deaths occur in hospitals in the first hour
- 4 M deaths p.a. (Cardiac, Road Accidents, Maternal, Suicidal attempts, Neonatal / Infant / Pediatric, Diabetic related, etc) due to absence of 4As :
 - **A**ccess to a universal toll-free number
 - **A**vailability of Life Saving Ambulance to reach quickly nearest and appropriate health facility
 - **A**ffectionate Care by trained paramedics (Compassion, Ability, Resourcefulness & Energy)
 - **A**ffordability by every citizen independent of income, religion and community
- Hence, GVK EMRI was born in April 2005

Innovative Process



- Developed detailed process understanding and well defined responsibilities through out the organization
- Maintained all information related to emergency in Patient Care Records (PCRs)
- Patient information is shared with the hospital on arrival
- 48 hour follow up with the patients admitted to hospital



COMPUTER SERVER ROOM

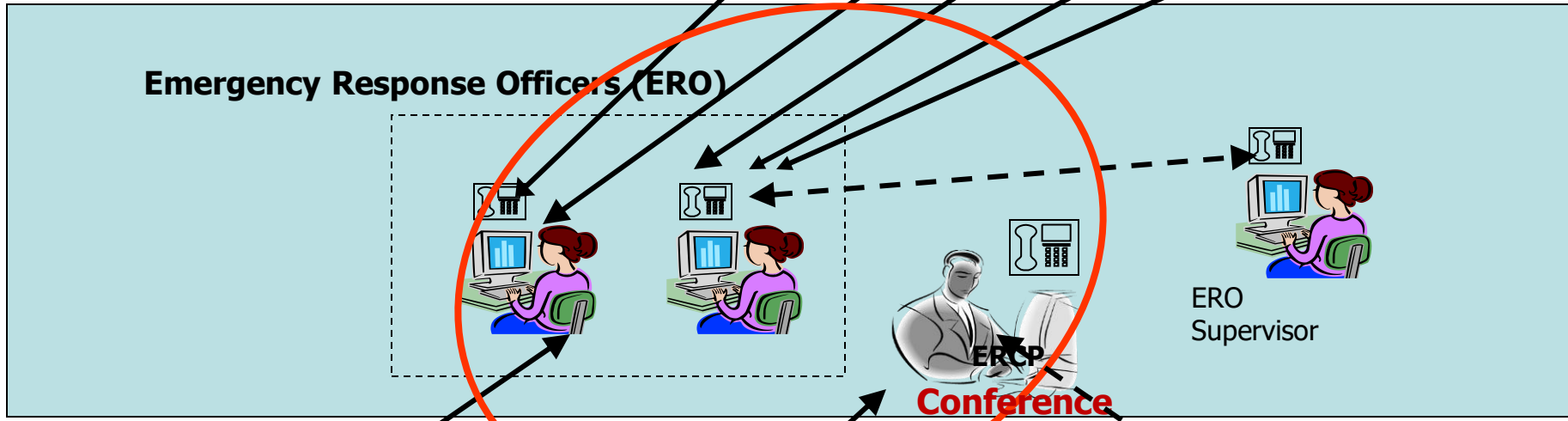
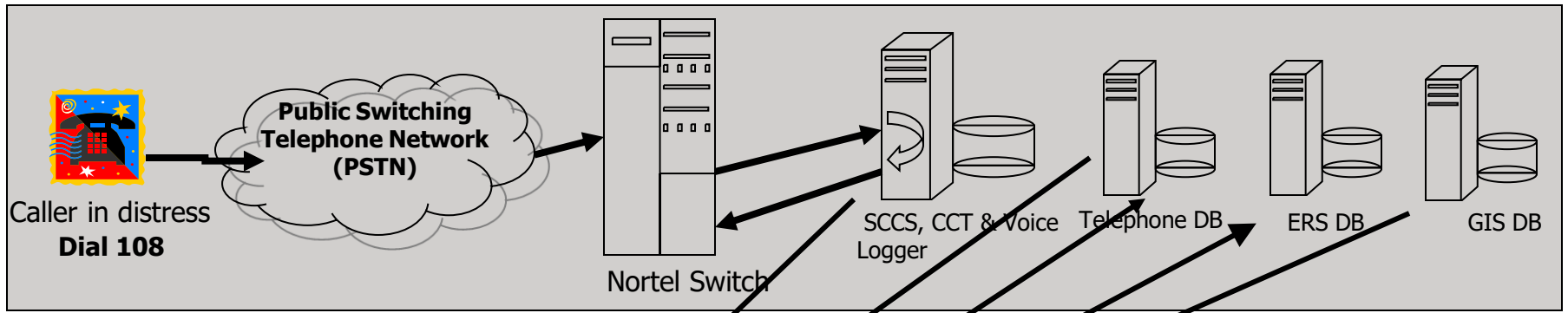

CCT: Communication Control Toolkit; **SCCS:** Symposium Call Centre Server; **ERCP:** Emergency Response Center Physician; **EMT:** Emergency Medical Technician



Building Blocks of GVK EMRI's Innovation



Three digit toll-free No.
Accessible from Land lines
and Mobile phones



Modern, spacious and open ERC



GIS / GPS to locate victim /
ambulance and hospital



Cost effective
ambulances
to provide quality
care
for Indian
emergencies
with facilities for
rescuing and
balancing patient
care with public
safety and patients
relatives comfort



Trained personnel for providing P

Launched on 15th Aug, '05 in Hyderabad and expanded to 15 States and 2 Union Territories

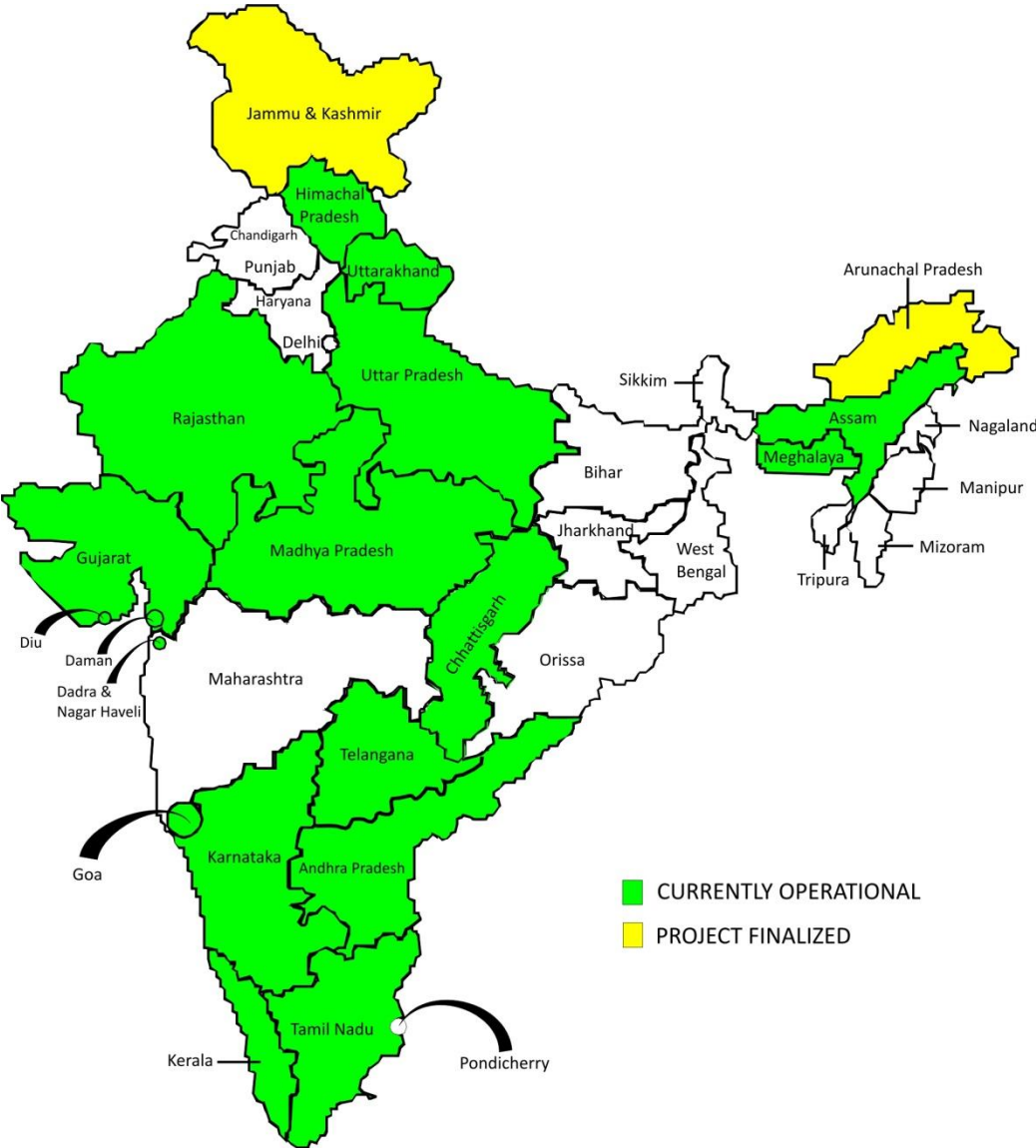

Population covered:	750 M
Emergencies attended:	48 M
Ambulances:	10796

COLLABORATION FOR TRANSFER OF KNOWLEDGE TECHNOLOGY KNOW-HOW, BEST PRACTICES, RESEARCH & TRAINING



Osmania University,
Hyderabad



Impact ..

Size

- One Center for population up to 200 M against one for every 0.05 M population in USA
- 750 M population covered in 15 States and 2 Union Territories (increased reach of health care in rural , hilly and tribal areas)
- Trained 2,20,29 Medical professionals like EMTs, Doctors, Nurses etc.
- 25,600 emergencies handled per day
- 10,796 Ambulances
- 44,510 GVK EMRI Associates
- Pregnancy related - 35%, Vehicular Trauma – 12%, Acute Abdomen – 13% Cardiac – 4%, Respiratory – 4%, Suicidal – 4%, Animal Bites 2%
- 925+ lives were saved per day (**18.27 lakhs**) and 25,560+ victims per day received timely, high-quality pre-hospital care
- 123deliveries assisted by EMTs everyday (**4.33 lakhs**)

Speed

- 96% calls taken in first 2 rings
- ~15 minutes (urban) and ~ 25 minutes (rural) Ambulances reached



- To respond to 30 million emergencies and save 1 million lives annually
- To deliver services at global standards through Leadership, Innovation, Technology and Research & Training
- Reduction in poverty and increase in Quality of Life can be achieved by Caring.
- This Joy of Giving back to society increases Satisfaction , Attachment and Morals



Launch of Neonatal Ambulances in Bhopal



108 Ambulance service recently Conducted a Triplet Delivery in its Dayapar Ambulance of Kutch Distict. On receiving the call Dayapar Ambulance reached the scene in just 12 Minutes and conducted safe delivery of two babies in the Ambulance enroute and the third one is conducted in CHC Dayapar. The Medical Officer at Dayapar CHC could only appreciate the safe and diligent job done by 108 team in the instant case and issued an letter of appreciation.

Original Article

Epidemiological study on cardiac emergencies in Indian states having GVK Emergency Management and Research Institute services

G. V. Ramana Rao, H. V. Rajanarsing Rao¹, G. Kesav Reddy¹, M. N. V. Prasad²

Emergency Medicine Learning Centre (EMLC) & Research, GVK Emergency Management and Research Institute, Devar Yamsal, Medchal Road, Secunderabad, Telangana, ¹Emergency Medicine Learning Centre (EMLC) GVK Emergency Management and Research Institute, Devar Yamsal, Medchal Road, Secunderabad, Telangana, ²Analytics GVK Emergency Management and Research Institute, Basaveshwaramagar Entrance, Magadi Road, Bangalore, Karnataka, India

ABSTRACT

Background: Emergency medical service (EMS) is critical for the healthcare system as it saves lives by providing care immediately. Rapid access to medical care after a major cardiovascular event decreases morbidity and mortality. GVK Emergency Management and Research Institute (GVK EMRI) is a pioneer in emergency management services operated as a public private partnership (PPP) with various state governments. GVK EMRI coordinates medical, fire, and police-related emergencies through a single toll-free number, 108, across 15 states and 2 union territories of India. **Material and Methods:** This is a retrospective study of reported cases of cardiac emergencies in 2015 across 11 states with GVK EMRI services: Andhra Pradesh, Telangana, Assam, Goa, Gujarat, Karnataka, Madhya Pradesh, Meghalaya, Rajasthan, Tamil Nadu and Uttarakhand. Descriptive statistics using frequencies, proportions and means were calculated. **Results and Discussion:** This study aimed to describe the epidemiology of cardiac emergencies presenting to GVK EMRI across 11 states in India in 2015. There were increased cases of cardiac emergencies reported by higher age group individual across all states. The mean age was reported between 43 years to 62 years across the states. In this study, men called EMS for cardiac emergencies more often than women, except in the state of Gujarat. A higher number of cardiac emergency cases were reported by individuals living below the poverty line in Andhra Pradesh, Telangana, Assam, and Goa. Often (82.8%) people called 108 greater than six hours of symptom onset. Variation in call volume per day was minimal between the days of the week. At 48 hours, there were 2,675 reported deaths (1.1%). **Conclusion:** The current study stresses the scale and seriousness of the emerging challenge of cardiac emergencies, with particular emphasis on socioeconomic deprived groups in the operated states of GVK EMRI.

Key words: Emergency medical services (EMS), cardiac emergencies, cardiovascular disease (CVD)

Results

In 2015, there were 248,828 cardiac emergency cases across these 11 states of GVK EMRI.

INDIA: SCA

720,000 per annum

INTRODUCTION

hypertension, which is expected to increase to 213 million